

Series Number:

4675

Type:
General Purpose

Stand:
Floor Stand

Mounting Style:
**Moveable or
Fixed Head**

Vessel Sizes, Gallons (Liters):
2.6 (10) and 5 (18.75)

Standard Pressure
MAWP Rating, psi (bar):
1900 (131)

Standard Maximum
Operating Temperature, °C:
225 w/ FKM O-ring
300 w/ FFKM O-ring
350 w/ PTFE Flat Gasket

Series 4675 General Purpose Vessel Systems, 2.6 & 5 Gallon

The Series 4675 General Purpose Vessels are the largest vessels offered by Parr Instrument Company. Vessel styles are offered in a moveable head or fixed head design. These vessels are available with an FKM O-ring seal for operating temperatures to 225 °C, and FFKM O-ring for temperatures to 300 °C, or with a flat, PTFE gasket for operating temperatures up to 350 °C maximum.

In the moveable head design, the vessel is held in a support system which minimizes the physical effort required to handle these heavy components. The hoist is attached to a support column which provides a convenient means for lifting the head and cylinder out of the stand. Vessels equipped with a bottom drain valve will probably remain in the heater most of the time, but can be lifted out when necessary.

The fixed head support stand features hinged split-rings that swing to either side allowing the head to remain fixed to the stand while a pneumatic lift allows the cylinder to be raised and lowered. When lowered, the cylinder can be slid forward for cleaning and servicing.

These vessels are generally used for pilot plant or for custom chemical production purposes, usually with a variety of attachments added to the basic units.

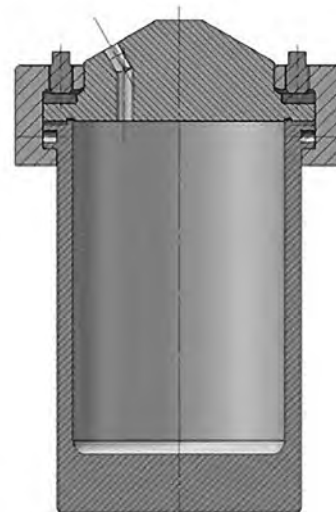

4675 Cross Section



Model 4675-10L General Purpose Vessel

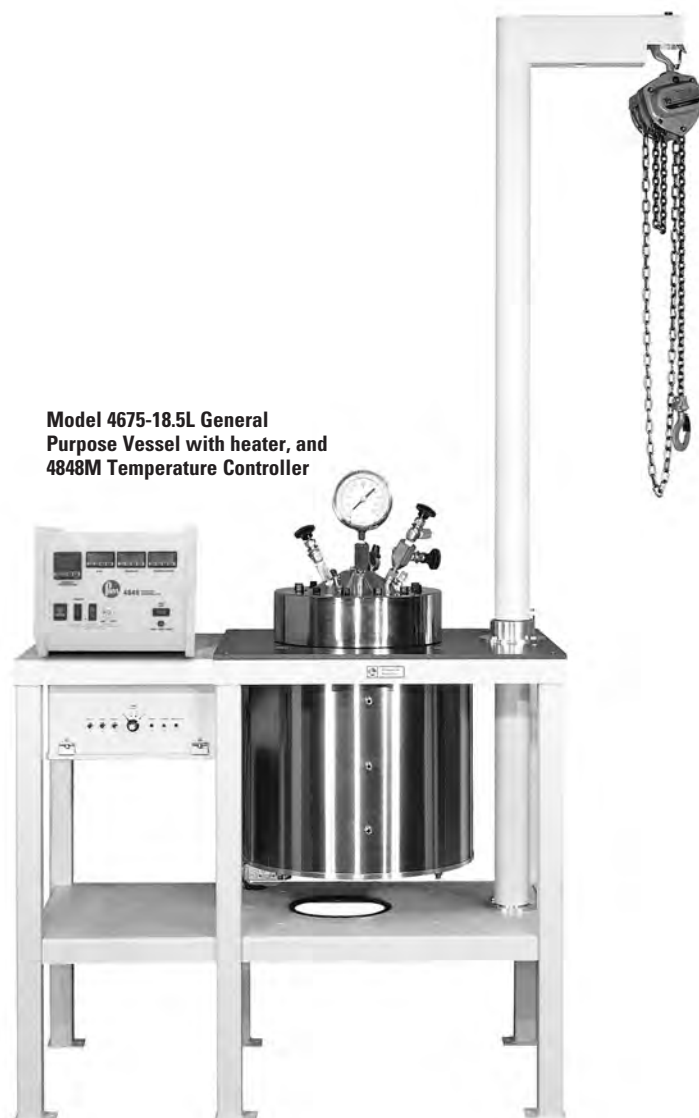

Model 4675-18.5L General Purpose Vessel with heater, and 4848M Temperature Controller

4675

Series 4675 Pressure Vessel Specifications		
Shaded bar indicates specifications that change within series.		
Model Number	4675	
Approximate Volume, Gallon (Liter)	5 (18.75)	2.6 (10)
Maximum Pressure (MAWP)	1900 psi (131 bar)	
Maximum Temperature		
with FKM O-Ring	225 °C	
with FFKM O-Ring	300 °C	
with PTFE Flat Gasket	350 °C	
with Flexible Graphite Flat Gasket	350 °C	
Vessel Details		
Mounting Style	Moveable or Fixed Head	
Closure	Split-Ring with 12 Compression Bolts	Split-Ring with 12 Compression Bolts
Head Opening Options	One head opening (1/4" NPT, 3/8" NPT, or rupture disc assembly port) Ports for valve, gage, rupture disc, and thermowell with thermocouple (VGR) Custom port option (Contact our technical sales department to discuss options)	
Maximum Head Openings	12 (Dependent on opening size, and required fittings)	
Valve Connections	1/4" NPT Female	
Pressure Gage, Size	4.5 inches	
Range	0-2000 psi (138 bar)	
Temperature Measurement	Thermowell	
Cooling Coil (optional)	Serpentine	
Bottom Drain Valve (BDV) (optional)	1" NPT	
Stand and Heater (optional)		
Stand Type	Table Floor Stand with manual hoist (moveable head) Floor Stand with Pneumatic Lift (fixed head)	
Heater Options	Band Heater, 3-zone Ceramic, 3-zone (moveable head) Flexible Mantle Heater (low temperatures <200 °C)	Band Heater, 3-zone Flexible Mantle Heater (low temperatures <200 °C)
Heater Power Requirements	Typical power requirements for Parr's large, electrically heated pressure vessels are 40 Amp single phase or 3-Phase power sources. Users are advised to have a qualified electrician determine and install an appropriate mains power supply for the large pressure vessel system. Large pressure vessel systems with lower electrical power requirements, such as low temperature applications are available for use with typical 20 amp 230 volt sources. Contact Parr Technical Sales staff for assistance with electrical specifications.	
Weights & Dimensions		
Cylinder I.D. x Depth, inches	9.5 x 16.25	7.75 x 12.2
Moveable Vessel Assembly Weight, pounds*	335	194
Fixed Vessel Assembly Weight, pounds*	336	195
Cylinder Weight, pounds	157	97
*Vessel weight is based on a vessel with VGR head fittings. Vessel weight will vary based on head configuration choice and fitting options.		
Other options available. See Ordering Guide, visit www.parrinst.com , or call for more information.		

Series 4675 Ordering Guide

An example order number for a vessel in this series is: **4675-5G-FG-SS-VGR-5000**

A composite identification number to be used when ordering a 4675 Series Pressure Vessel System can be developed by combining individual symbols from the separate sections below. For more information on how to use this ordering guide, please see page 27.

A Vessel Volume

-2.6G	2.6 Gallon, 7.75" ID
-5G	5 Gallon, 9.5" ID

B Head Mounting Style

-No Symbol	Moveable Head (Standard configuration)
-FH	Fixed Head

C Gasket / Maximum Temperature

-T	PTFE Flat Gasket, 350 °C
-OV	FKM O-ring, 225 °C
-OK	FFKM O-ring, 300 °C
-FG	Flexible Graphite Flat Gasket, 350 °C

D Material of Construction

-SS	T316 Stainless Steel
-C20	Alloy 20
-MO	Alloy 400
-IN600	Alloy 600
-IN625	Alloy 625
-HB	Alloy B-2 / B-3
-HC	Alloy C-276
-NI	Nickel 200
-TI2	Titanium Grade 2
-TI4	Titanium Grade 4
-ZR702	Zirconium Grade 702
-ZR705	Zirconium Grade 705

See page 10 or 24 for complete list of available alloys.

E Head Configuration

-1/4	One head opening, 1/4" NPT port, plugged
-3/8	One head opening, 3/8" NPT port, plugged
-RD	Rupture disc port with rupture disc assembly & disc
-VGR	Valve on gage adapter, pressure gage, rupture disc assembly, & thermocouple and thermowell
-NS	Non-standard, custom head opening

F Optional Fittings & Custom Options (List all needed)

-VD	Single Valve on head w/ dip tube (VGR Required)
-DVD	Double Valve Assembly on head w/ dip tube (VGR Required)
-SC	Serpentine Cooling Coil
-BDV	Bottom Drain Valve (1" NPS)
-CAD	Internal Catalyst Addition Device
-XCAD	External Catalyst Addition Device
-SCP	Solids Charging Port (Ball Valve)
-RC	Reflux Condenser
-RTC	Reflux/Take-Off Condenser

G Pressure Gage (VGR Required)

-No Symbol	None
-2000	2000 psi / 138 bar
-1000	1000 psi / 69 bar
-600	600 psi / 40 bar
-200	200 psi / 14 bar
-100	100 psi / 7 bar

H Stand Type

-No Symbol	None
-FS	Floor Stand, Table Support with Manual Lift (Moveable Head)
-FSEH	Floor Stand, Table Support with Electric Hoist (115 VAC) (Moveable Head)
-FSP	Floor Stand with Pneumatic Lift (Fixed Head)

I Heater Options (require stand)

-No Symbol	None
-C3	Ceramic, 3-zone (moveable head, 5 Gallon only)
-B3	Band Heaters, 3-zone
-WJ	Welded Jacket
-FM	Flexible Mantle Heater, 1-zone (200 °C Max. Temp.)

J Controller

-No Symbol	None
-4838	PID Control, Ramp & Soak Programming, and Data logging with Software (RS-485 to USB cable not included). For use with one additional display module. (Available only for 10 L/18.75 L with Flexible Mantle Heater or 10L with Band Heaters)
-4848M	With Slave Box, PID Control, Ramp & Soak Programming, and Data logging with Software (RS-485 to USB cable not included). For use with up to three additional display modules. (Recommended for 10 L with Band Heaters. Required for 18.75 L with Ceramic or Band Heaters)

See Chapter 6 for complete list of Controller options.

K Controller Options (Check all needed)

-PDM	Pressure Display Module
-HTM	High Temperature Cut Off Module
-ETLM	External Temperature Limit Module
-SVM	Solenoid Valve Module (for cooling control)
-A1925E4	RS-485 to USB Converter (required for data logging)
-A1925E6	RS-485 to USB Converter, isolated, 30-ft
-A2208E	RS-485 Daisy Chain for Multiple Controllers (Must be used with A1925E6)
-A3504HC	SpecView Software Package for 4838/4848 Controller

L Electrical Supply for Heater and/or Controller

-No Symbol	None
-230	230 VAC, Single Phase (Typically 40A supply required)
-400	400-415V 3-Phase "Y"

M Certifications

-No Symbol	No Certification
-ASME	ASME Documentation
-CE	CE Documentation
-P	Parr Certification